

REAR SUSPENSION

SHOCK ABSORBERS

REMOVAL

1. Put the car on the lift and raise.
2. Unscrew the lock nut (4) and nut (3) securing the shock absorber to the trailing arm (5), retrieve the cup (2) and rubber cushion (1).

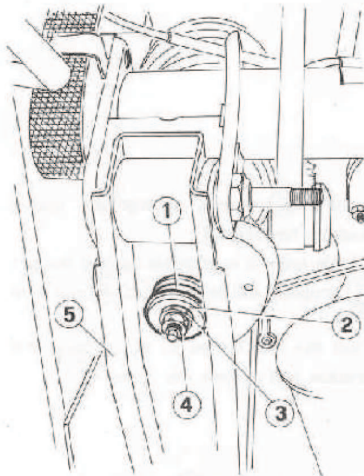

- 1 Rubber cushion
- 2 Cup
- 3 Nut
- 4 Lock nut
- 5 Trailing arm

3. Lower the car and, working from within the passenger compartment remove the rear upholstery (1) at the side to be worked on.

4. Unscrew the two screws (2) securing the door (3) to the bodywork and remove it.

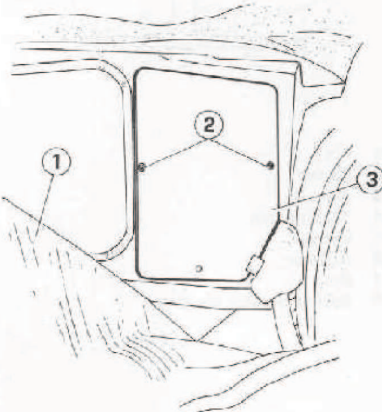

- 1 Rear upholstery
- 2 Screws
- 3 Door

5. Unscrew the two screws (1) securing the shock absorber (2), at the top, to the bodywork.

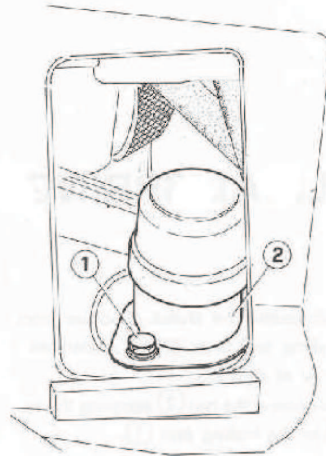

- 1 Screw
- 2 Shock absorber

6. Get hold of the shock absorber (1) sliding it out from above.

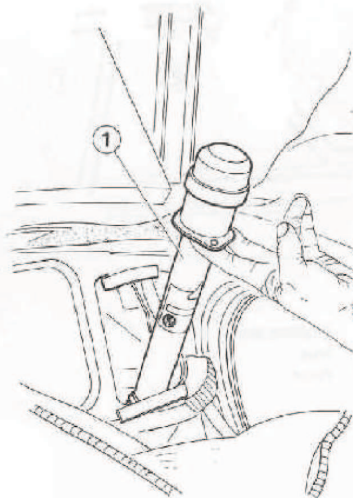

- 1 Shock absorber

7. If necessary, dismantle the shock absorber by sliding off the upper cowling (1) and unscrewing the lock nut (2) and the nut (3). Then slide off the various parts as shown in the figure.

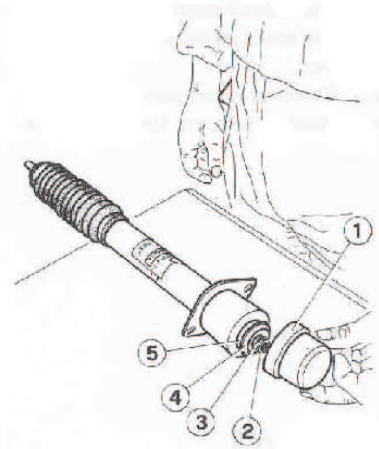

- 1 Upper cowling
- 2 Lock nut
- 3 Nut
- 4 Cup
- 5 Rubber cushion
- 6 Carrier
- 7 Rubber cushion
- 8 Cup
- 9 Shock absorber casing
- 10 Bellows



Install the new shocks in the conventional position with the covered portion on the top.

REAR SUSPENSION

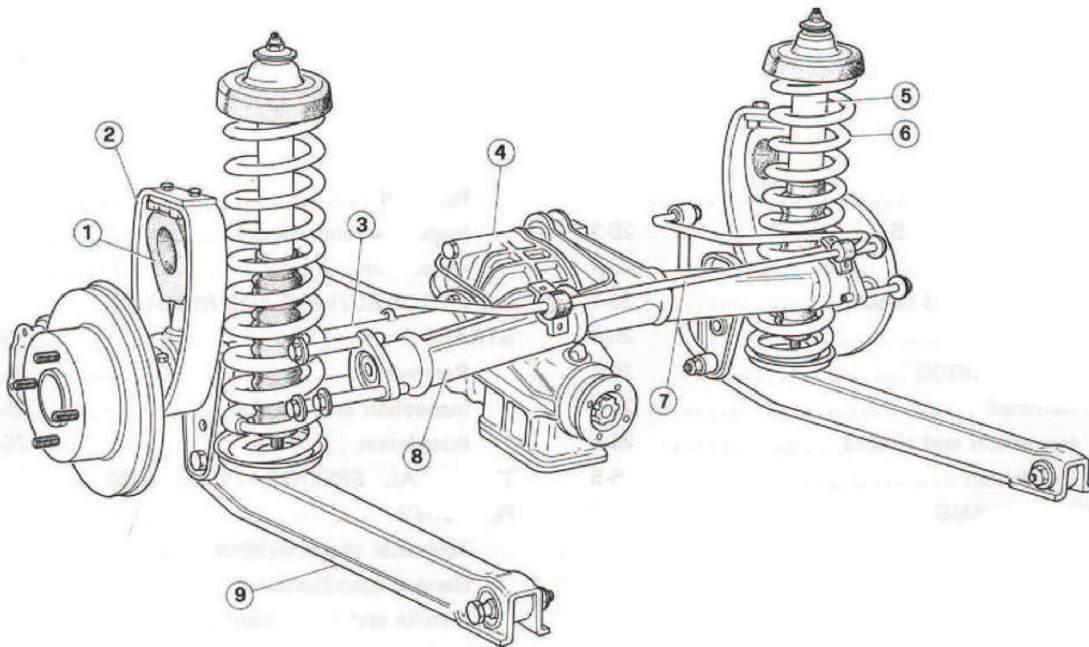

- 1 Limit stop buffer
- 2 Rebound strap
- 3 Rear axle

- 4 Differential
- 5 Shock absorber
- 6 Spring

- 7 Stabilizer bar
- 8 Reaction triangle
- 9 Trailing arm

www.AlfaShockabsorbers.com